

STRUKTUR ORGANISASI PT. SAN CENTRAL INDAH

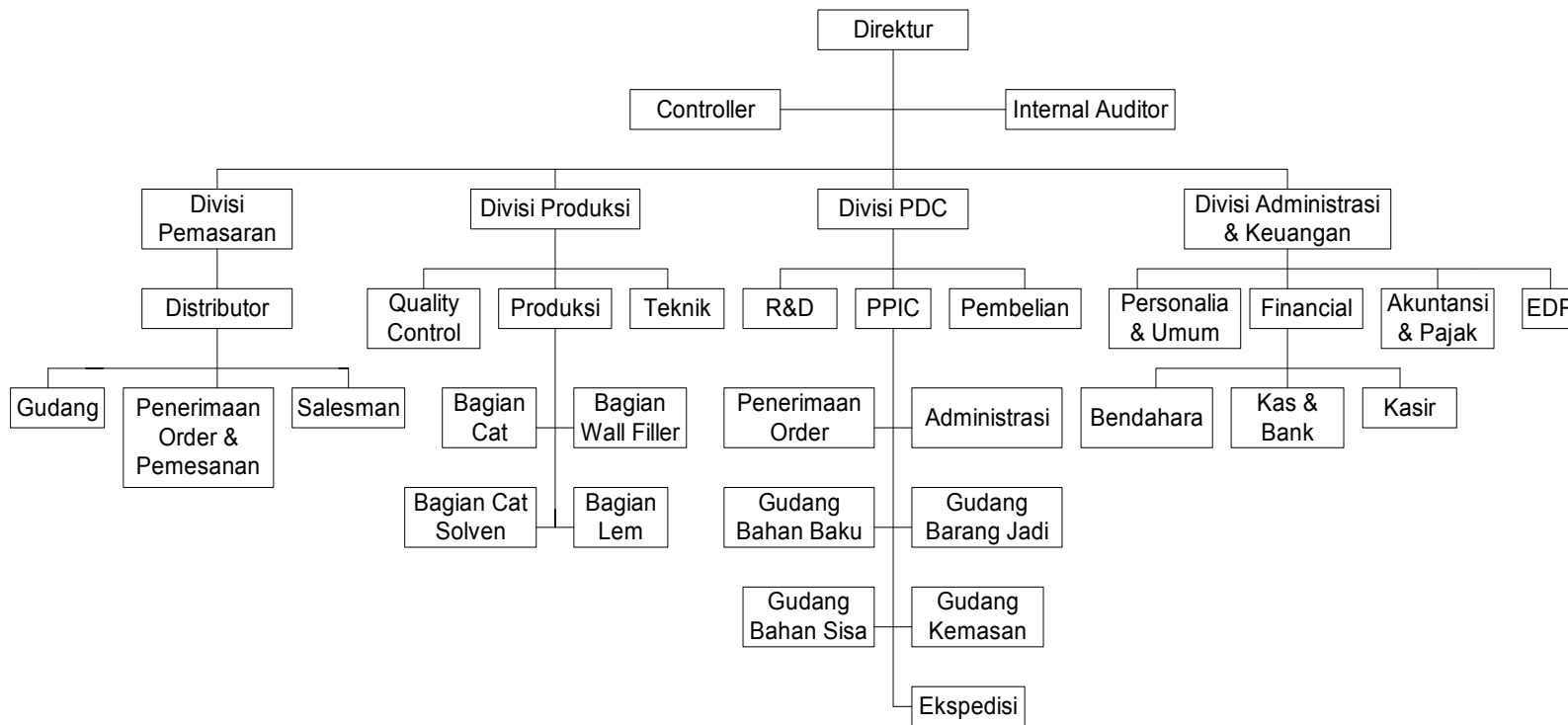

FLOWCHART PENJUALAN KREDIT

PT. SAN CENTRAL INDAH

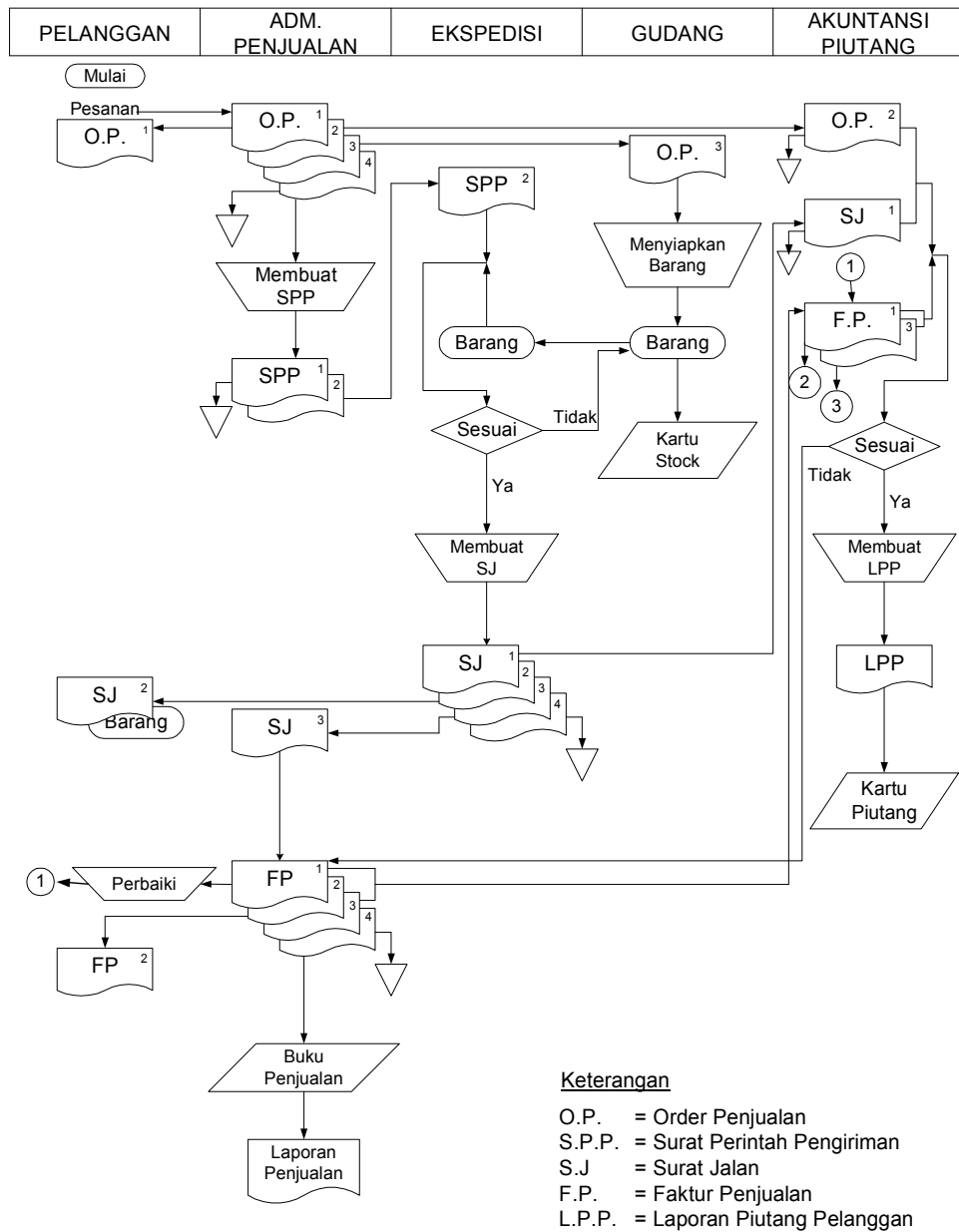

FLOWCHART PENAGIHAN PIUTANG

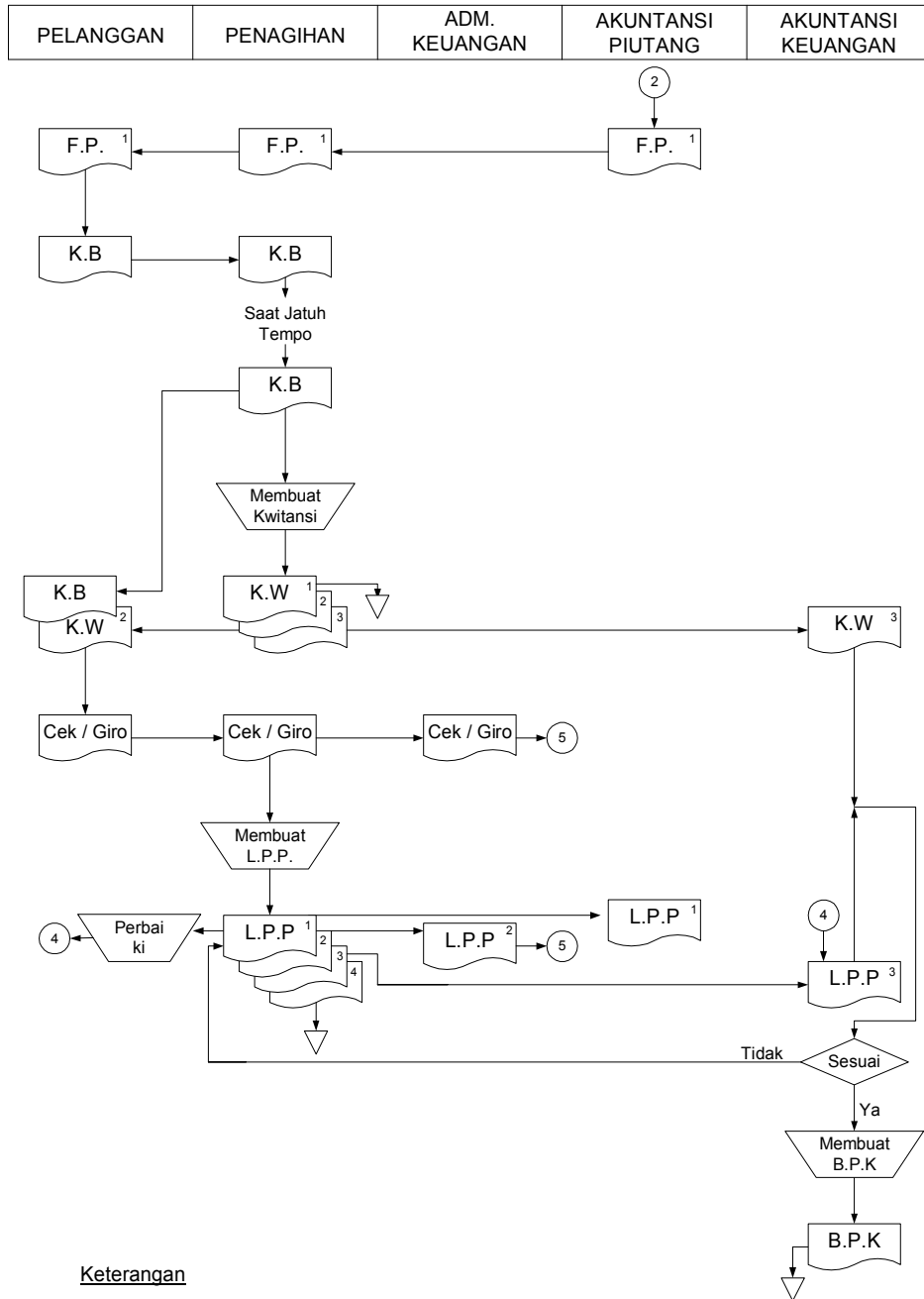

- Keterangan**
- K.B. = Kontra Bon
 - K.W. = Kwitansi
 - L.P.P. = Laporan Perincian Penagihan
 - B.P.K. = Bukti Penerimaan Kas

FLOWCHART PENERIMAAN UANG

ADM. KEUANGAN	BANK	AKUNTANSI PIUTANG	ADM. PENJUALAN
---------------	------	-------------------	----------------

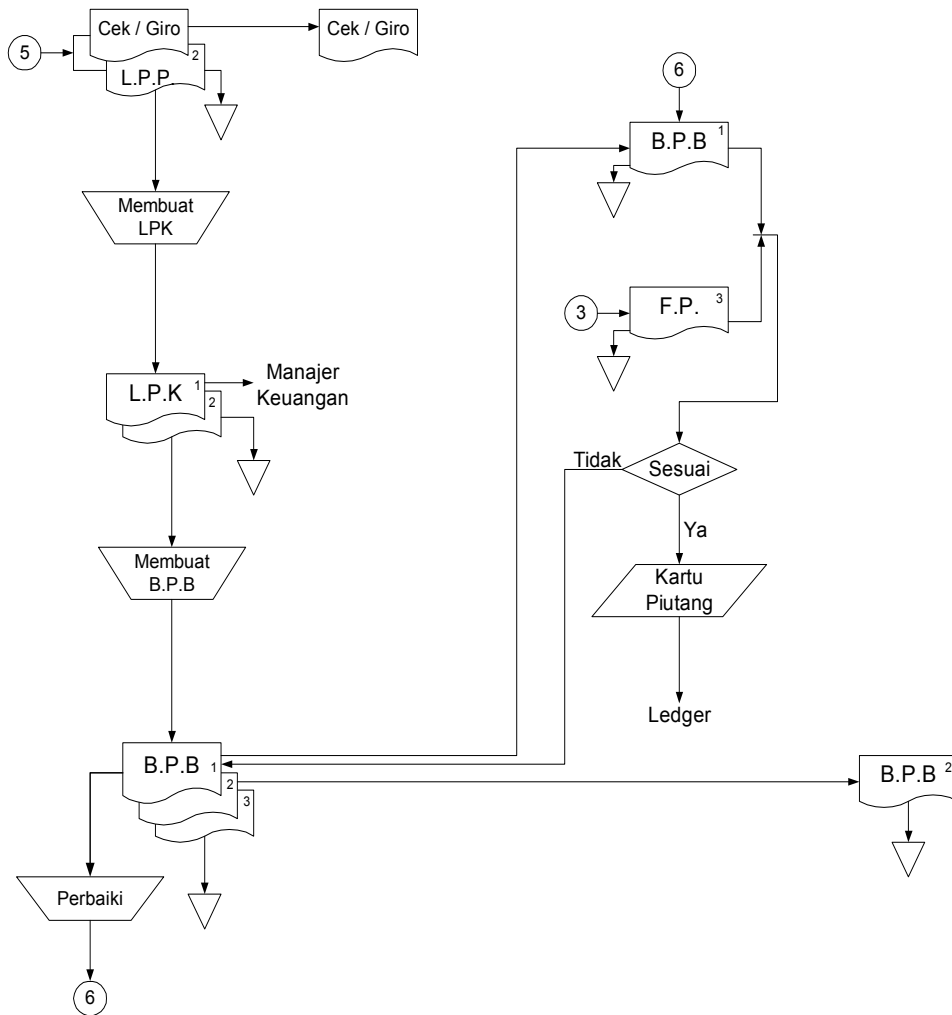

Keterangan

- L.P.P = Laporan Perincian Penagihan
- L.P.K = Laporan Penerimaan Bank
- B.P.B = Bukti Penerimaan Bank
- F.P = Faktur Penjualan

FLOWCHART PROSEDUR PENJUALAN KREDIT MENURUT KRISMIAJI (2002,277)

