

LAMPIRAN A
PROGRAM PLC

Program lists and diagrams

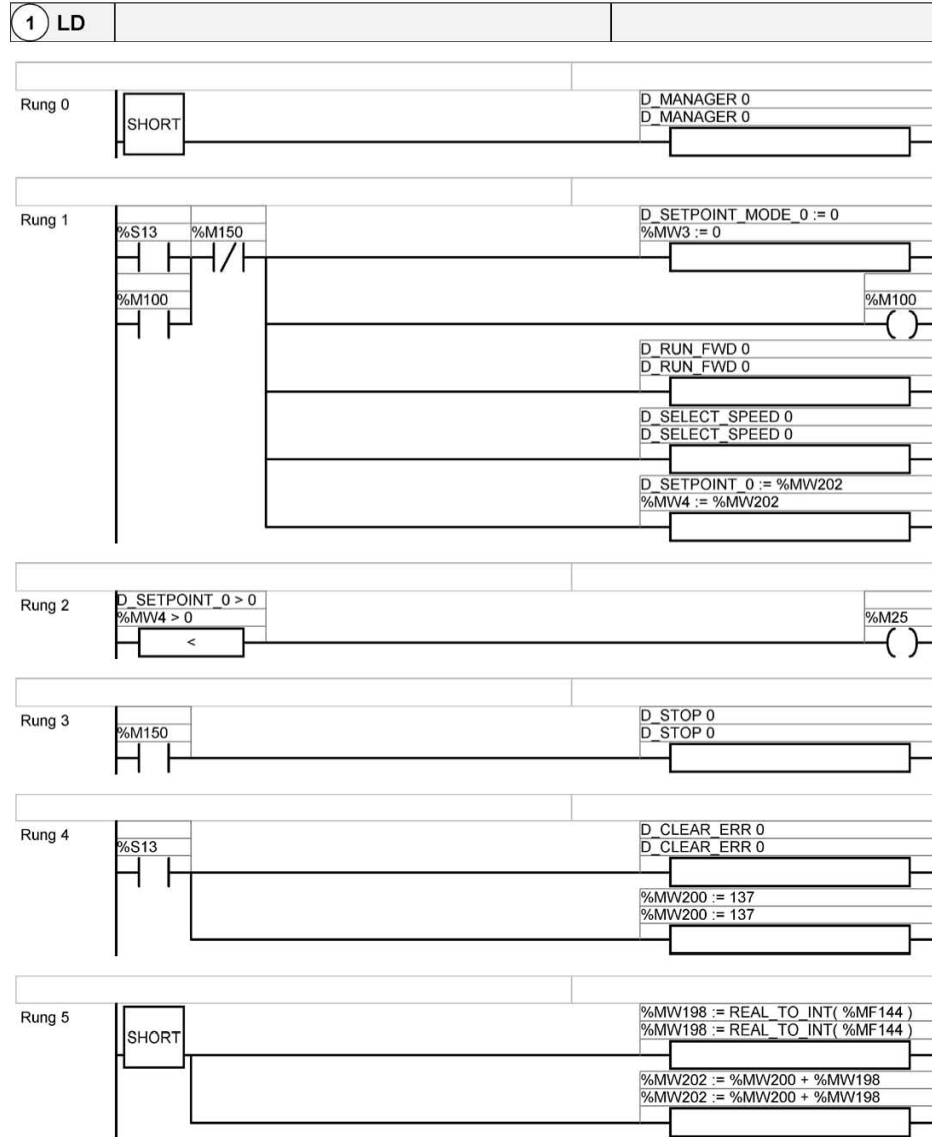



2 LD

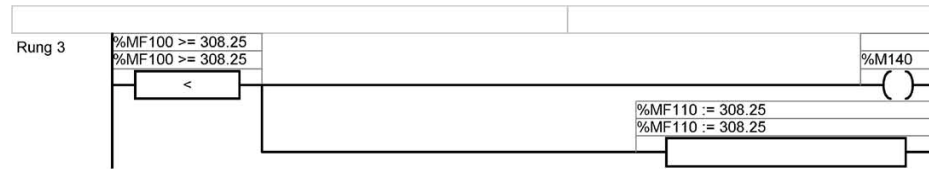
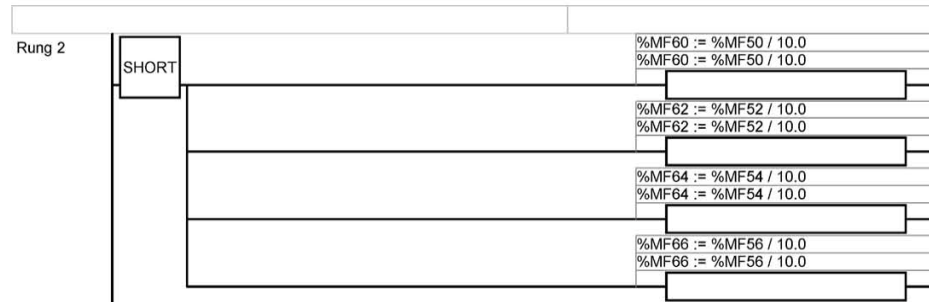
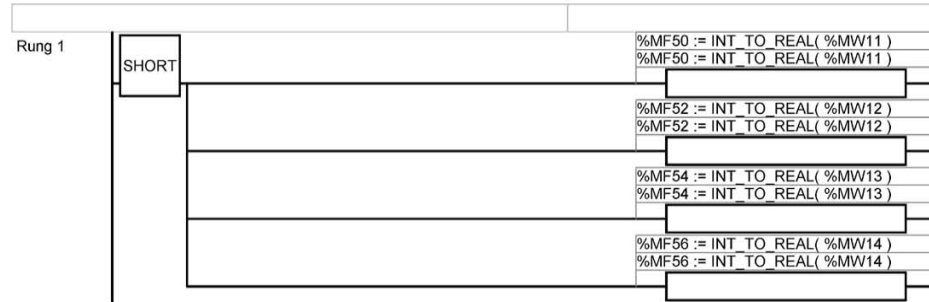
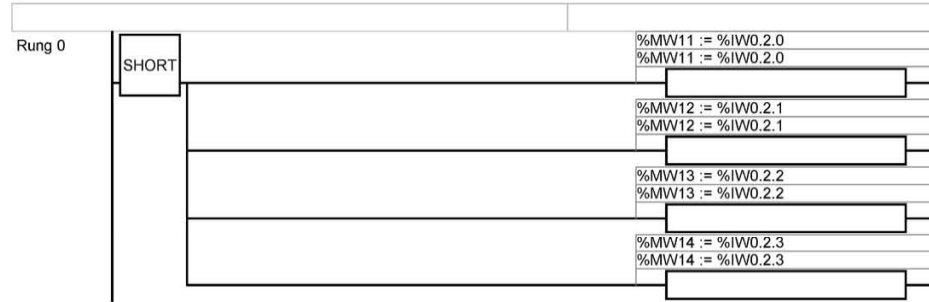

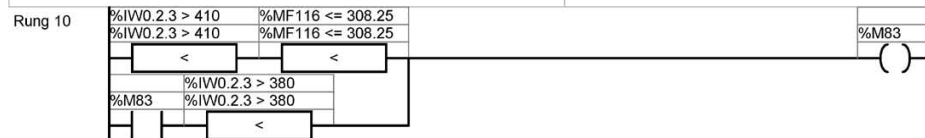
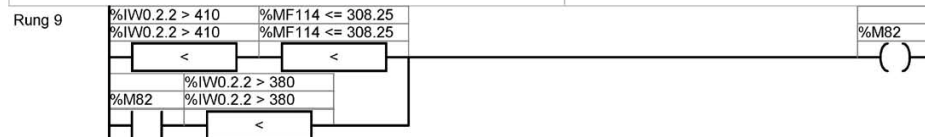
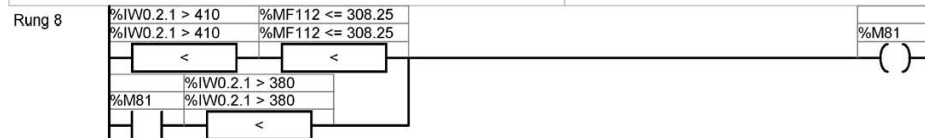
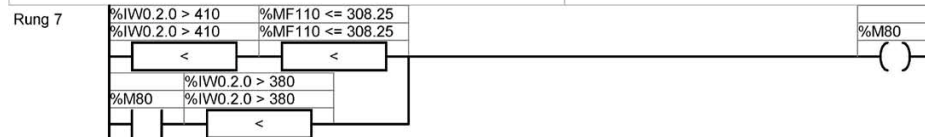
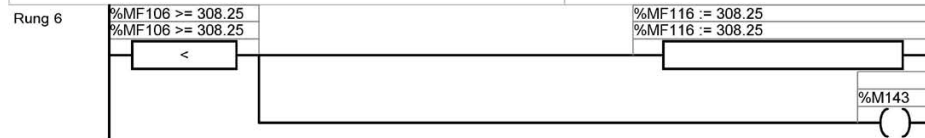
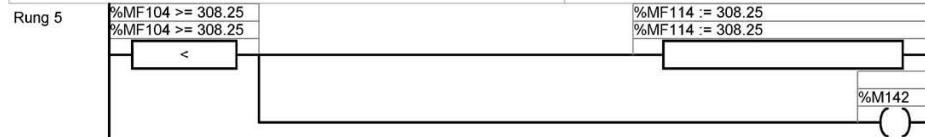
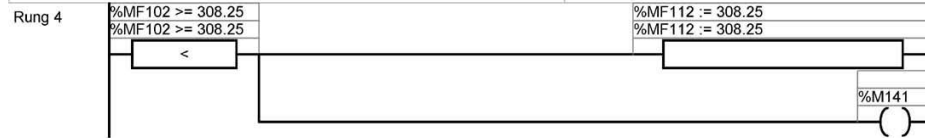

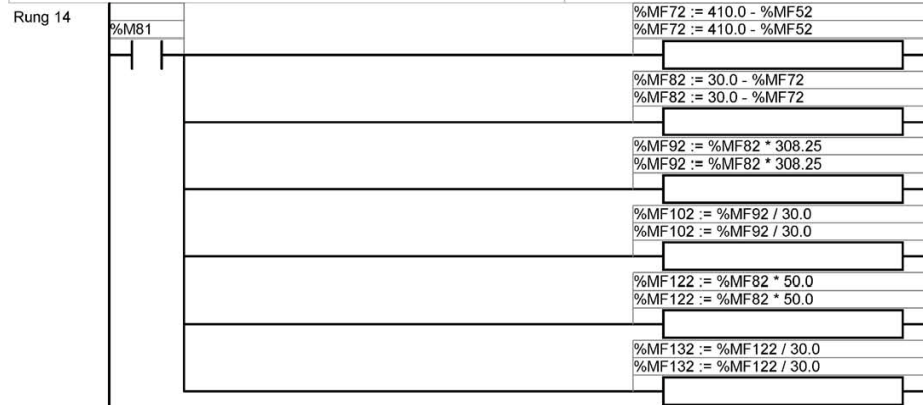
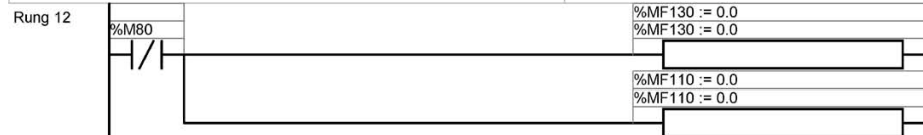
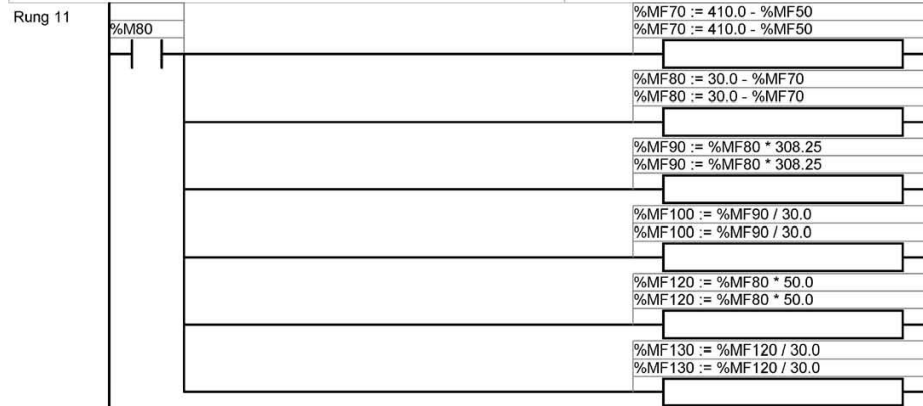

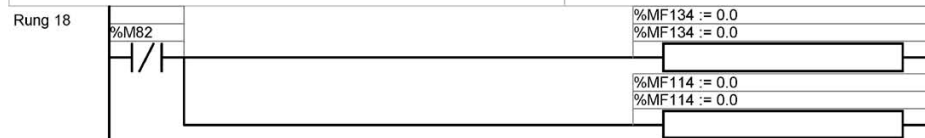
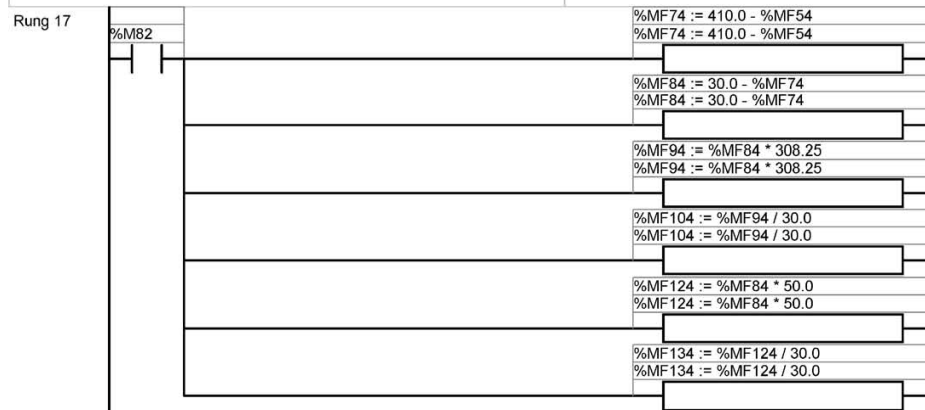
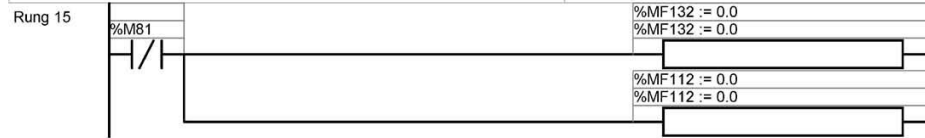

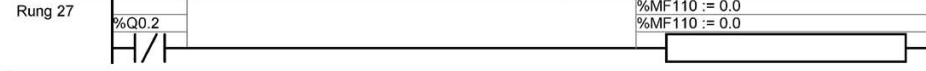
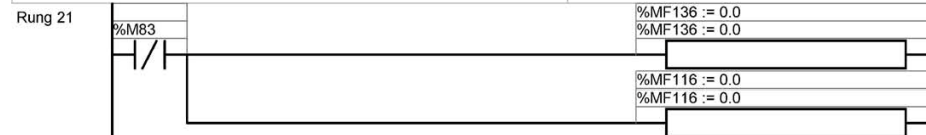
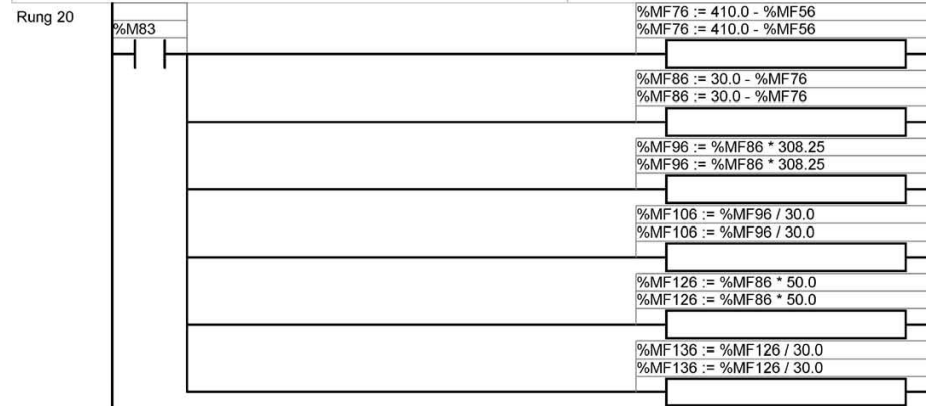

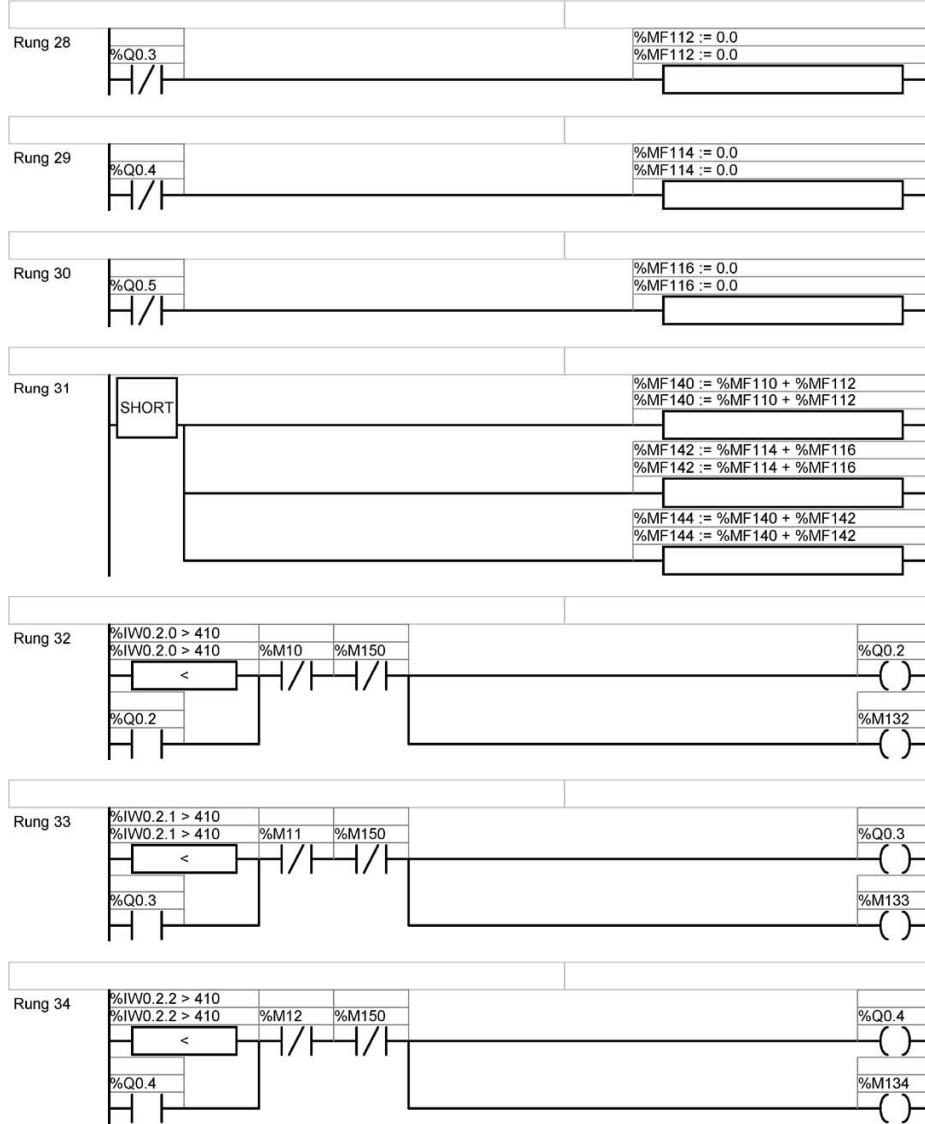

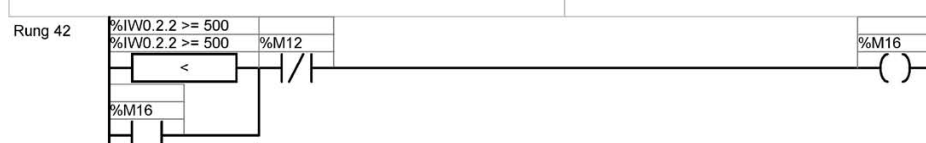
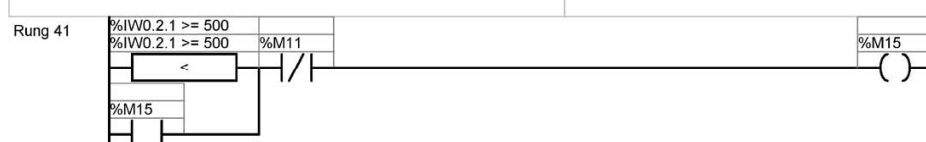
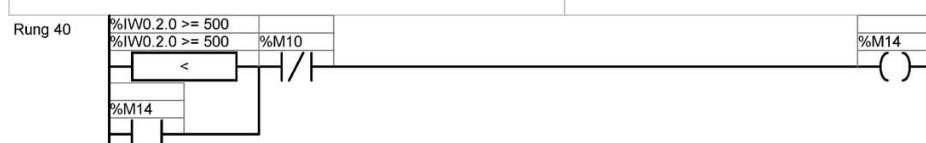
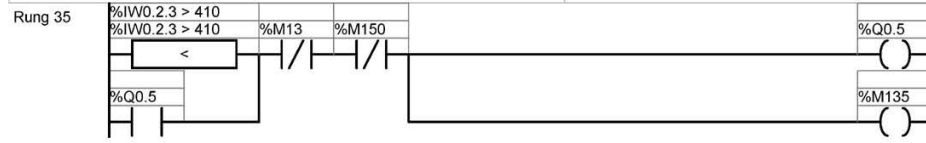



3 LD

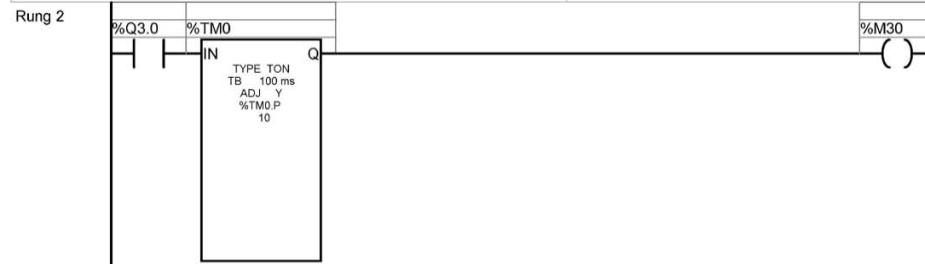
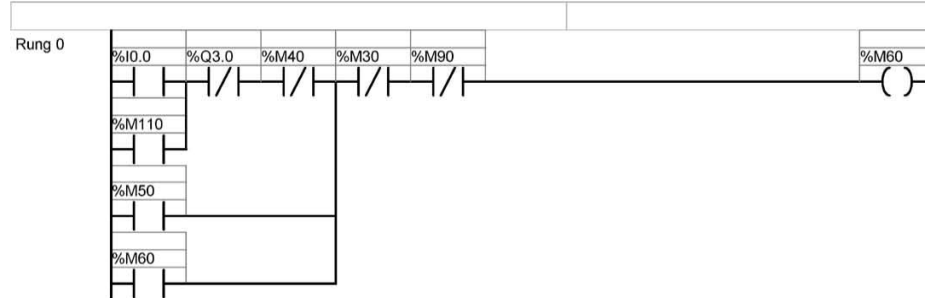

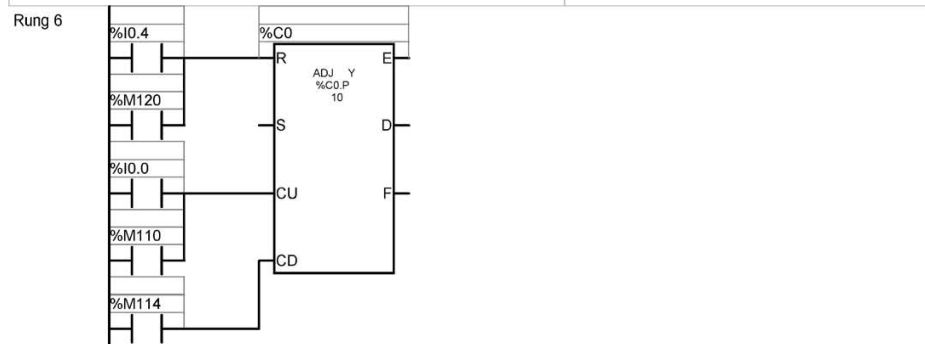
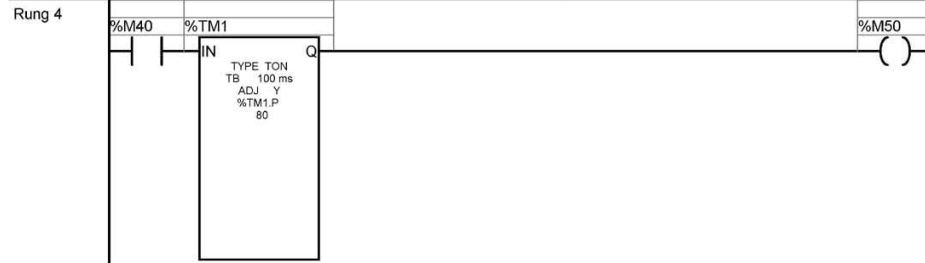

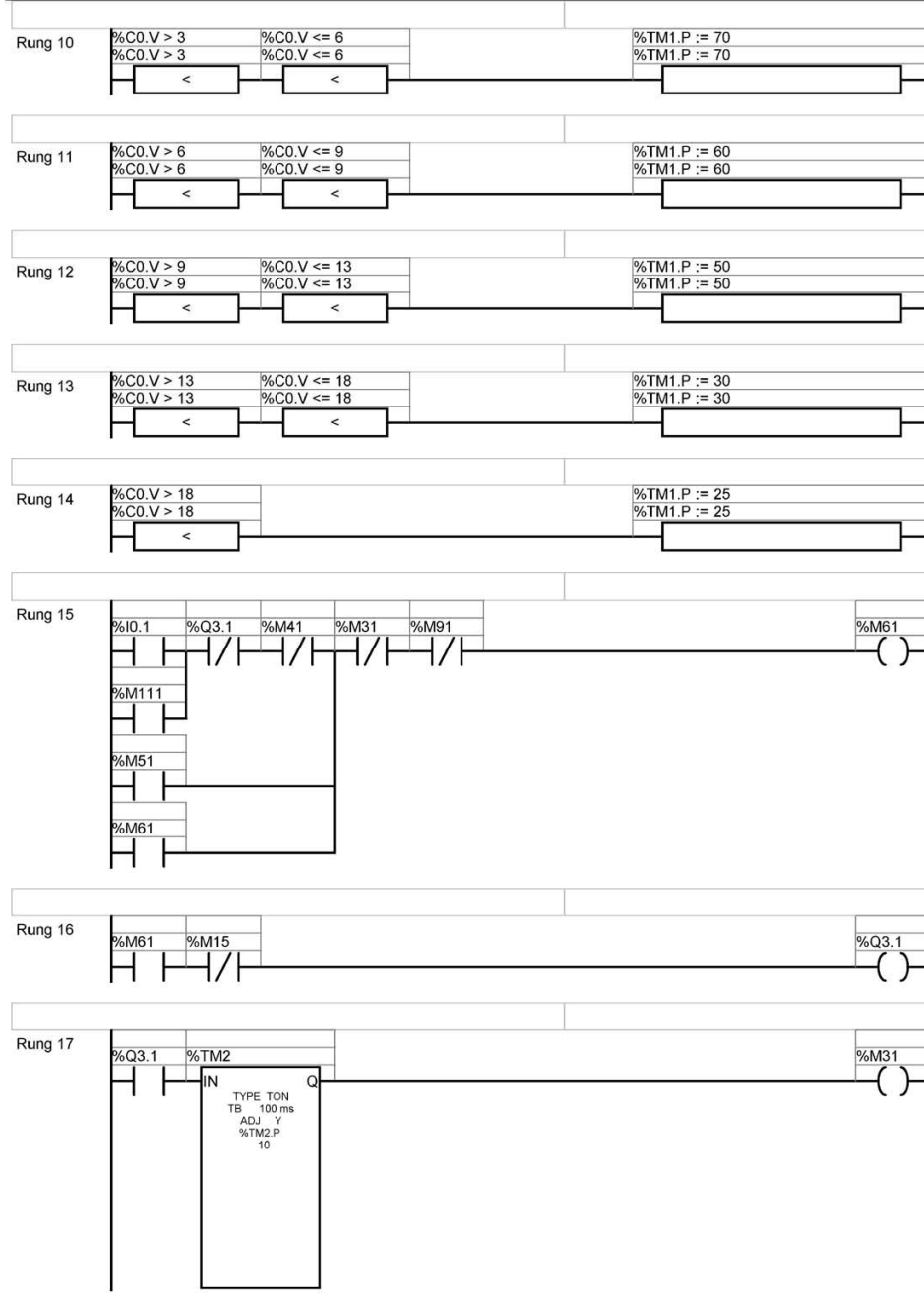

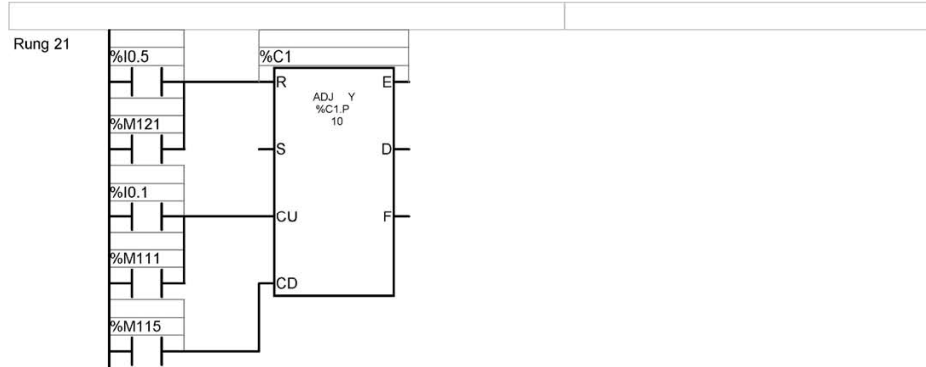
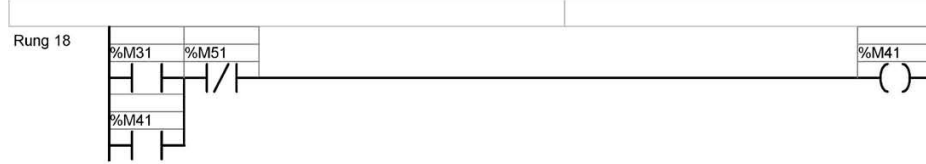

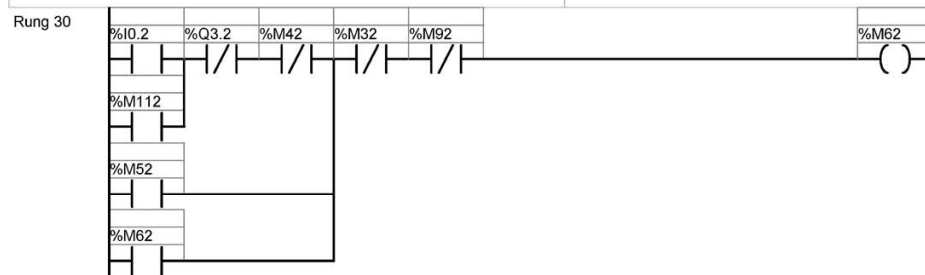
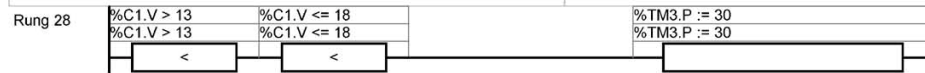

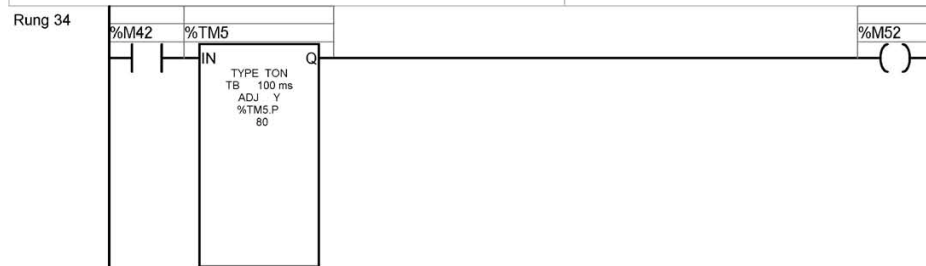
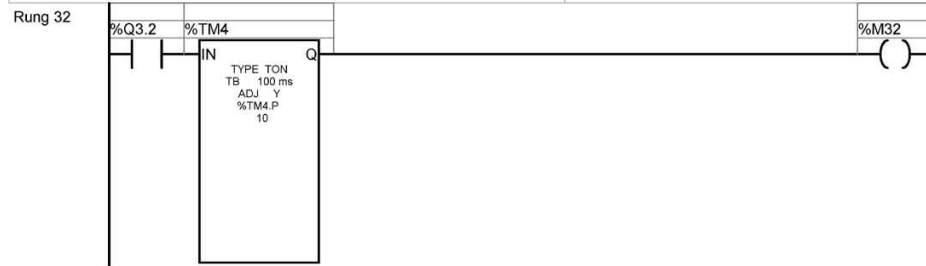

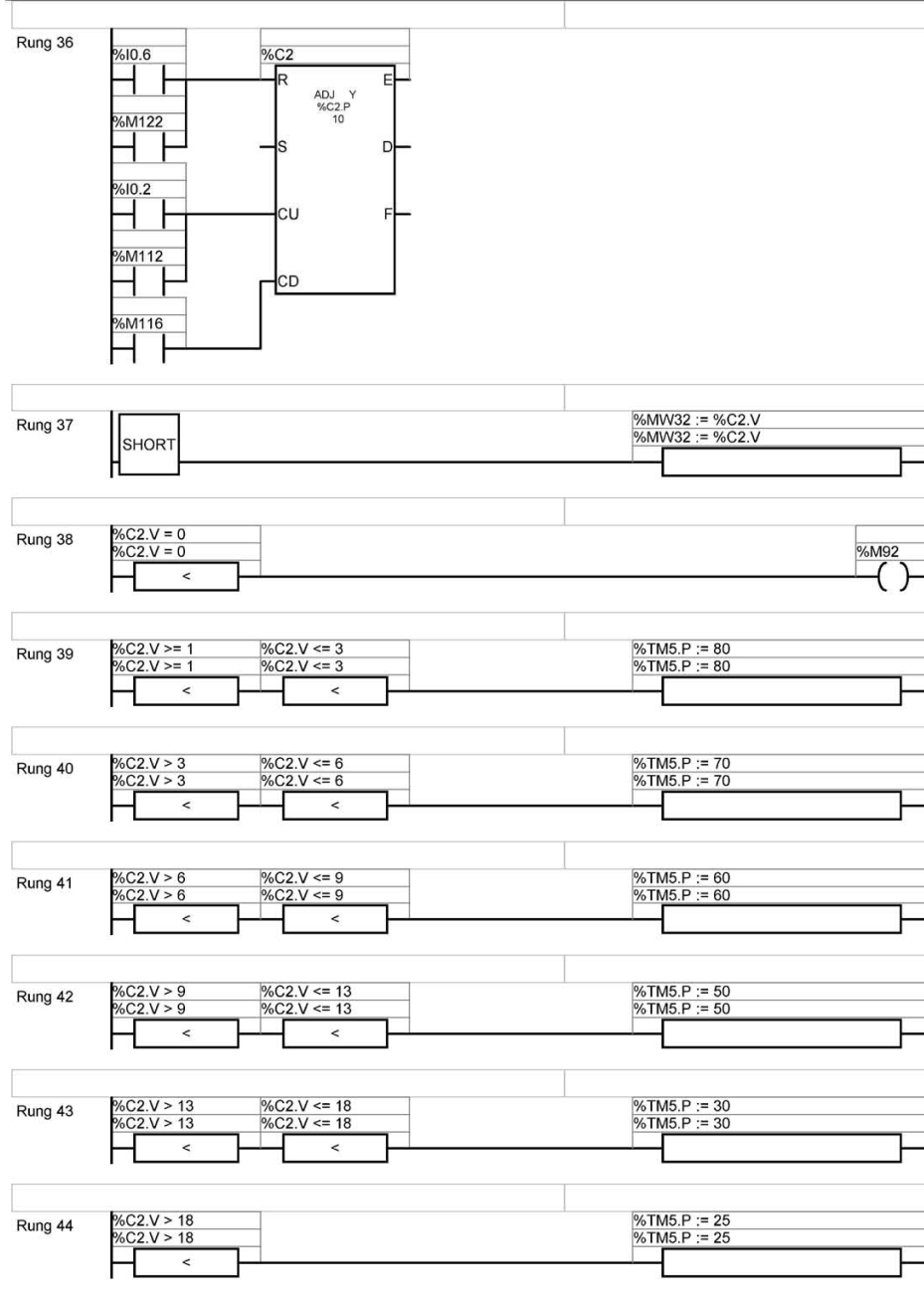

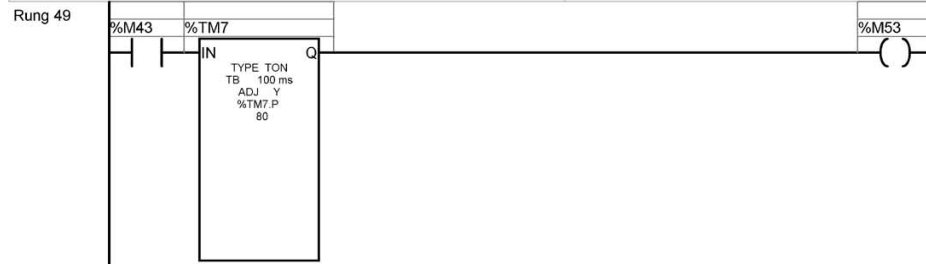
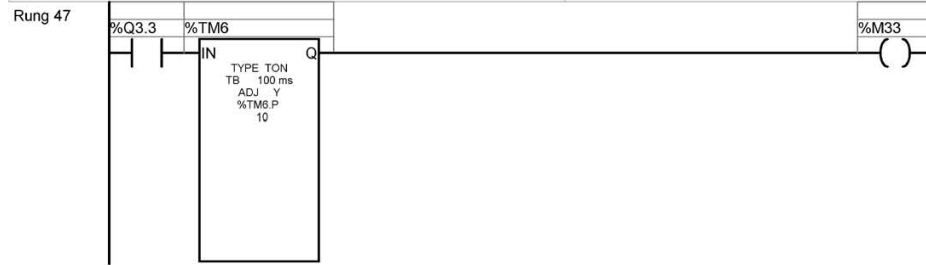
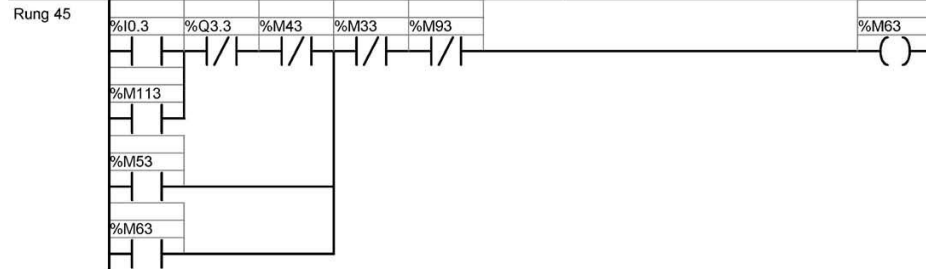

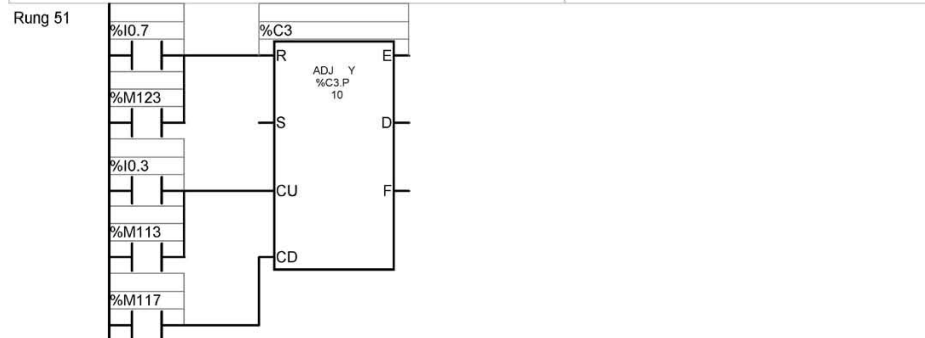

9/24/2010

8/3/2007

My project.xpr

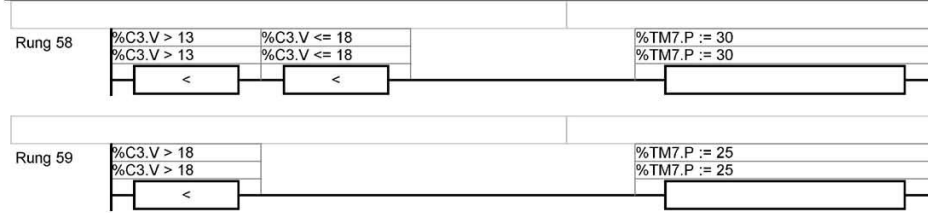

LAMPIRAN B
FOTO PERALATAN

PLC TWIDO

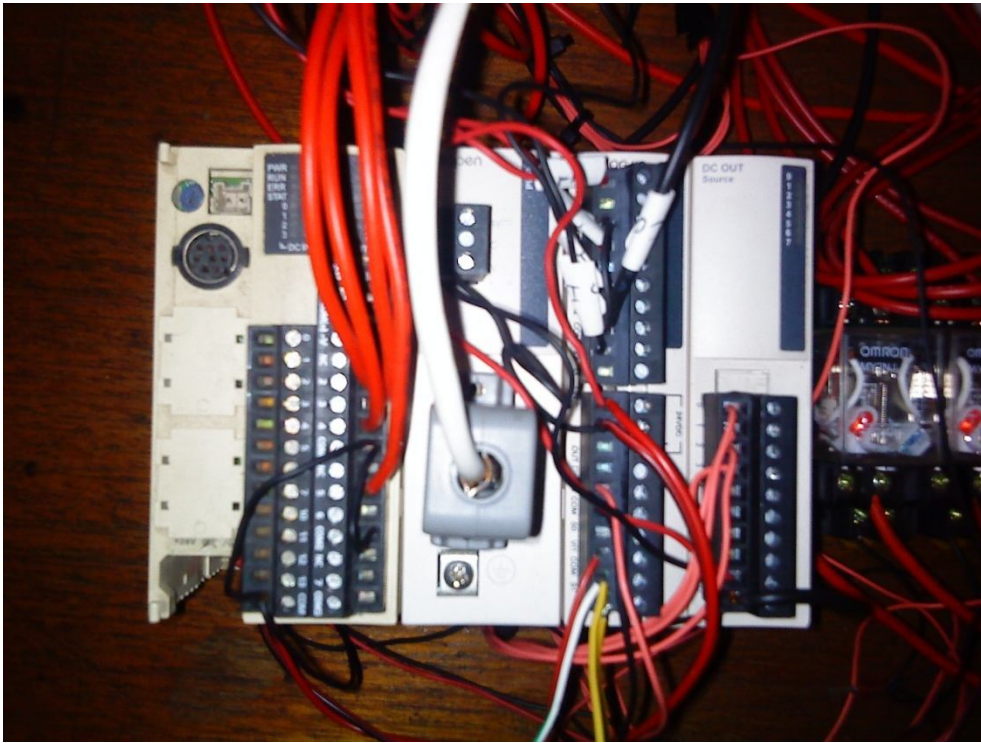

VSD ALTIVAR-31



PC YANG DIGUNAKAN



ALAT-ALAT YANG DIGUNAKAN

