

14. Comparative Study of Riprap Model Design for Scour Protection of Bridge Pier

by Cut Talitha Salsabila Nuraprili, Robby Yussac T, Alexander Yovan
Suwono

Submission date: 03-Apr-2023 04:39PM (UTC+0700)

Submission ID: 2054476435

File name: 14._Comparative_Study_of_Riprap.pdf (895.36K)

Word count: 1619

Character count: 8130

Comparative Study of Riprap Model Design for Scour Protection of Bridge Pier

Cut Talitha Salsabila Nurapriili^a, Robby Yussac Tallar^b and Alexander Yovan Suwono^c
Civil Engineering Department, Maranatha Christian University, Jl. Surya Sumantri.65, Bandung, Jawa Barat Indonesia

Keywords: Comparative Study, Local Scouring Riprap, Model Design.

Abstract: Streams have an important function for human by providing irrigation, electricity, etc. Streams also have the sediments within that typically flow following the direction of water velocity. The differences in characteristics among streams have also been clear since it can be changed easily due to climate change, or other natural factors. Streams also can change in dimension according to the surrounded environmental conditions, for example local scouring caused by bridge pier. And then by using riprap is the most common countermeasure to prevent local scouring. Riprap is a method that can be used to prevent erosion in streams or other conditions that have water flows with high velocity. Therefore, the purpose of this study is to compare two models riprap design around the pier for scour protection. The riprap models that were compared are rectangular and circle shaped. The condition used in this study is clear water condition, under sediment-based layer design, and riprap layer thickness. The experimental study was used to compare both riprap model design. The result of this study indicates that circle shape model riprap is better than a rectangular shape. Further studies are necessary regarding the effect of flow type, cross-sectional shape, or other related variables.

1 INTRODUCTION

Streams are one of the sources of water on this earth and have an important function for humankind, it has various characteristics and many models. For streams flows, especially in urban areas, these streams have bridged that function to connect roads separated by streams (Tallar & Suen, 2017).

Bridge has more than one pier which functions as a load-bearing from the bridge itself and other loads such as live loads and dead loads. However, presence of a pier, the type of flow of water will be changed from horizontal to vertical, (Hao, 1993) so that local scouring occurs around the pier and will result in the lifting of the base of material around the pier and resulting in damage to the foundation on the bridge pier.

Since the bridge piers that damaged due to the scouring, then require to prevent or control bridge pier local scouring. Riprap is one of the solutions for local scouring (Figure 1). Riprap is one of the



Figure 1: Local scouring around the pier (From: Bintangtimur.net).

methods used for preventing local scouring (Rashno, Zarrati, & Tabarestani, 2020). The material of riprap is rocks arranged around the pier (Figure 2). With used riprap around the pier, then it can reduce down flow jet on bottom sediments against local scouring. This study has been conducted, these studies generally inspect the design of riprap size in clear water scour conditions, for example Chiew (1995).

^a <https://orcid.org/0000-0002-5641-5796>
^b <https://orcid.org/0000-0001-7307-3348>
^c <https://orcid.org/0000-0002-2577-8519>

A riprap modeling experiment will be carried out in this study. The study aims to compare the two riprap models that are rectangular and circular. The positioned of two models riprap is around the pier to prevent the impact of local scouring. This experimental study aims to compare both models and the results will show that the circular shape is better than the rectangular. (Unger & Hager, 2006)



Figure 2: Example of riprap around the pier (From: istiarto.staff.ugm.ac.id).

2 METHODS

To find a better riprap model, then this study will show it. By using a comparative of the two models that rectangular and circular shapes, using the same amount of two discharge. Is supposed to take both Q_{25} and Q_{75} to make sure. Besides, another parameter that would be used in this study, likes the size of the gravels that would use in the riprap model design, which would be used in the same size for both models. (Khademghaeinya, Abrishami, Zarrati, Karimaei Tabarestani, & Mashahir, 2020)

2.1 Sieve Analysis

Sieve analysis was used in this study to find out these gravels size for riprap model design. By using many different sizes of sieve, likes 19,1 mm or until 0,075 mm (Table 1). So, this analysis is important, to ensure each layer of riprap is the same size as previously determined.

2.2 Discharge Curve Analysis

To find out which discharge can restrain the flow that exists in the streams, it can experiment with using a discharge curve to find to get the best 2 results of

discharge or Q . At the time when did the experiment with discharge curve analysis, try multiple discharges 25% discharge (Q_{25}), 50 % discharge (Q_{50}), and 75% discharge (Q_{75}).

2.3 Scenario Riprap Model Design

The riprap models that were compared in this study are rectangular and circular. Riprap placed under sediment-base layer design. The thickness of these two riprap models is 30 mm and the dimension will be used in 28 cm or 280 mm (diameter for circular shape and length for rectangular shape) and the diameter of the pier used in this study is 8 cm. In this study, the condition of the water is on clear water scour, it usually happens when low flow discharge. This experimental study was used to compare two models design to knows which models better to prevent local scouring around the pier.

3 RESULT AND DISCUSSION

3.1 Sieve Analysis

Sieve analysis was an experiment in the laboratories, to find out the gravel riprap size. Then dr_{50} , from sieve analysis data can be decided to gravel size to use in riprap models design.

Table 1: Sieve Analysis.

No. Sieve mm (inch)	Cumulative Soil Retained (%)	Cumulative Soil Passing (%)
19.1 mm (3/4")	0	100
12.7 mm (1/2")	81.871	18.129
9.52 mm (3/8")	96.315	3.685
4.75 mm (No.4)	99.079	0.921
2.36 mm (No. 8)	99.089	0.911
1.18 mm (No.16)	99.119	0.881
0.6 mm (No. 30)	99.219	0.781
0.3 mm (No. 100)	99.274	0.726
0.15 mm (No. 100)	99.479	0.521
0.075 mm (No. 200)	99.750	0.250
PAN	100	0

By using the Aggregate Distribution Curve, dr_{50} of the riprap gravels is 10,5 mm. These two riprap models are used in this comparative study.

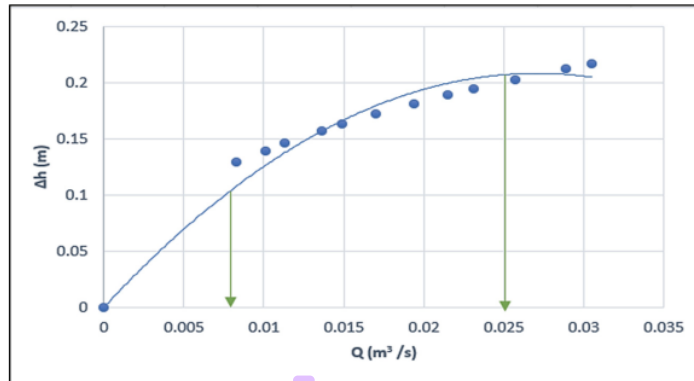

Figure 3: Discharge curve analysis.

3.2 Discharge Curve Analysis Results

From the discharge values in Table 2, the results of the discharge curve analysis are obtained. The curve is depicted in Figure 3.

Table 2: Discharge Data.

Δh	Discharge (Q) (m^3/s)
0.2169	0.0305
0.2124	0.0289
0.2026	0.0257
0.1941	0.0231
0.1886	0.0215
0.181	0.0194
0.1719	0.017
0.1631	0.0149
0.1569	0.0136
0.1459	0.0113
0.1394	0.0101
0.1292	0.0083

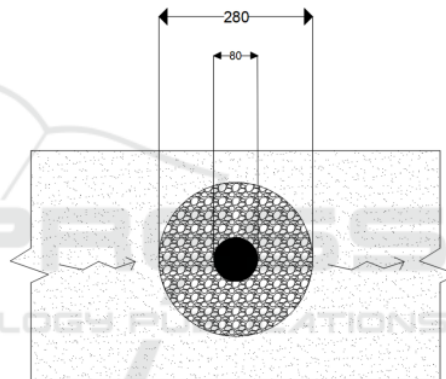

Figure 4: Illustration of riprap with circular shape (top view, unit: mm).

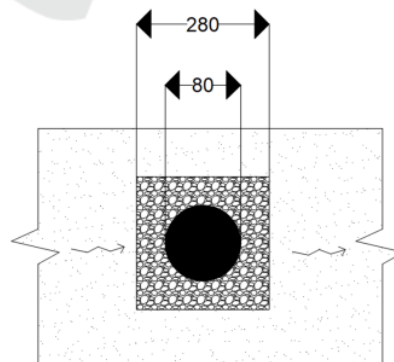

Figure 5: Illustration of riprap with rectangular shape (top view, unit: mm).

3.3 Scenario Riprap Model Design

The riprap models that were compared are circular (Figure 4) and rectangular shaped (Figure 5). In this study, the condition used is clear water condition, under sediment-base layer design, and riprap layer thickness. The riprap layer thickness used is 30 mm.

4 CONCLUSIONS

The study shows that a riprap with a circular shape is stronger than a rectangular shape. For 25% discharge, the riprap with circular shape has 22% stronger than a riprap with rectangular shape. For 50% discharge, the riprap with circular shape has 28 % stronger than a riprap with rectangular shape. For 75% discharge, the riprap with circular shape has 33 % stronger than a riprap with rectangular shape. Therefore, the circular shape has presented about 20-35% stronger with discharge under all discharge condition compared to the rectangular shape.

The study also indicates that the riprap layer will degrade to an equilibrium intensity below a given constant discharge condition. Further studies are necessary regarding the effect of flow type, the size of bridge piers, such as the other shapes in which one is stronger, and other related variables that can be used in this study.

ACKNOWLEDGEMENTS

The author wishes to express their hearty thanks to Civil Engineering Department, Maranatha Christian University for the support and to LPPM (*Lembaga Penelitian & Pengabdian Masyarakat*), Maranatha Christian University.

REFERENCES

- Hao, L. (1993). Hydraulic Computation for Riprap Protection against Scouring around Bridge Piers [J]. *Journal of Sediment Research*, 3.
- Khademghaeinya, G., Abrishami, J., Zarrati, A., Karimaei Tabarestani, M., & Mashahir, M. (2020). Riprap design at bridge piers with limited scouring. *Scientia Iranica*, 27(2), 588–595.
- Rashno, E., Zarrati, A. R., & Tabarestani, M. K. (2020). Design of riprap for bridge pier groups. *Canadian Journal of Civil Engineering*, 47(5), 516–522.
- Tallar, R. Y., & Suen, J.-P. (2017). Measuring the aesthetic value of multifunctional lakes using an enhanced visual quality method. *Water*, 9(4), 233.
- Unger, J., & Hager, W. H. (2006). Riprap failure at circular bridge piers. *Journal of Hydraulic Engineering*, 132(4), 354–362.

14. Comparative Study of Riprap Model Design for Scour Protection of Bridge Pier

ORIGINALITY REPORT

6%

SIMILARITY INDEX

5%

INTERNET SOURCES

3%

PUBLICATIONS

%

STUDENT PAPERS

PRIMARY SOURCES

1

www.scitepress.org

Internet Source

4%

2

acikbilim.yok.gov.tr

Internet Source

1%

3

Honkura, Kohei, and Tatsuo Horiba. "Study of the deterioration mechanism of LiCoO₂/graphite cells in charge/discharge cycles using the discharge curve analysis", *Journal of Power Sources*, 2014.

Publication

1%

4

www.dergipark.ulakbim.gov.tr

Internet Source

1%

Exclude quotes Off

Exclude matches Off

Exclude bibliography On

14. Comparative Study of Riprap Model Design for Scour Protection of Bridge Pier

GRADEMARK REPORT

FINAL GRADE

/0

GENERAL COMMENTS

Instructor

PAGE 1

PAGE 2

PAGE 3

PAGE 4
